



**DEEP WELL**  
**LINESHAFT**  
**TURBINE PUMPS**

# ***Vertical Lineshaft Turbine Pumps***



## **APPLICATIONS:**

- ✓The vertical turbine pump was initially developed for agricultural purposes.
- ✓Since then, improvements, special designs and materials have made it ideal for municipal and plant water supply, drainage, flood control, pipeline pumping, power plant service, petrochemical applications, high pressure pumping and other industrial uses.
- ✓Wherever a liquid needs to be pumped upward from underground water tables (deep well pumps); manmade underground storage (caverns); and open bodies of liquid such as oceans, rivers, lakes, cooling ponds, tanks and sumps.
- ✓Vertical turbine pumps are also used in inline systems, pipelines, booster and low NPSH systems.

# ***Vertical Lineshaft Turbine Pumps***



## **ADVANTAGES**

1. Vertical pumps require minimum floor space.
2. The NPSH available can be the lowest level to satisfy the NPSH requirements of the pump.
3. No priming required, the pump bowl assembly is submerged in the fluid being pumped.
4. The vertical turbine is highly versatile and adaptable in terms of both location and pump length
5. The variety of materials and construction possibilities to meet special requirements (such as corrosion resistance) is virtually unlimited.
6. Pressure requirements are easily met by staging.
7. The vertical turbine pump is adaptable to various codes.
8. Easily modified for changing hydraulic conditions

# ***Vertical Lineshaft Turbine Pumps***



9. Low operating speeds.
10. No messy, complex hydraulic systems.
11. Worldwide service availability
12. Nemitsas vertical turbine designs record high pump efficiencies.
13. Standard motors of all makes are easily matched and supported on all Nemitsas discharge heads

Nemitsas vast range of vertical turbine models are designed to suit a great variety of, capacity, head conditions and horsepower applications.

# Vertical Lineshaft Turbine Pumps



## Features and Benefits

- *Cast-iron, bronze and S/S fitted bowl assemblies from 2" to 12"*
- *Enclosed or open lineshaft with threaded or flanged column pipe.*
- *Enclosed or open impellers.*

## Applications

- *Irrigation*
- *Municipal water supply*
- *Booster system*
- *Dewatering*



# ***Vertical Lineshaft Turbine Pumps***



## **Materials**

A wide range of standard materials are available including:

- Cast parts – cast iron, carbon steels, 316SS, duplex, super duplex and bronze
- Shafts – 316SS, 416SS, Monel, K-Monel and Nitronic 50
- Fabrications – carbon steel, duplex and 316SS
- Bearings – carbon, cast iron, epoxy, Nitronic 60, bronze and rubber

# Vertical Lineshaft Turbine Pumps

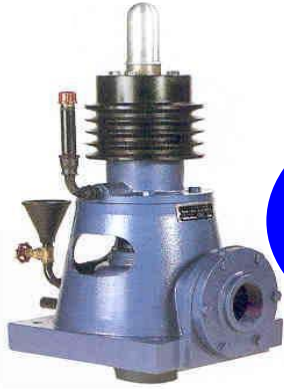

**KF-KV**

**NEMITSAS PUMP**  
Open Line-Shaft  
Threaded Column

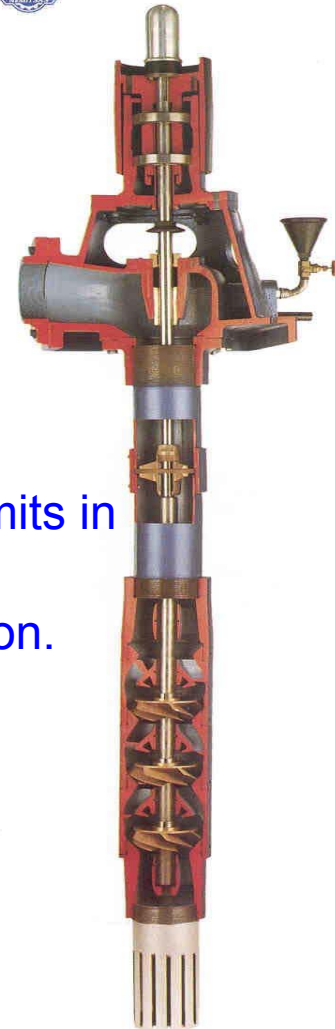

Introducing a complete KF and KV series of engineered cast discharge head, designed to meet the needs of our customers.

- Heavy Duty - Designed for stability.
- Designed to Reduce Hydraulic Friction Losses.
- Discharge columns and shafts can be accommodated within wide limits in these designs.
- The rotation is anticlockwise and a ratchet prevents reverse rotation.

## **Specifications – For greater depths please consult the manufacturer.**

Capacities: ..... @ max flow up to 140 m<sup>3</sup>/hr

Head: ..... @ zero flow up to 210 meter

Horsepower: ..... Up to 160 hp

Temperature: ..... Up to 82 °C

Drives: ..... V or F Ropes with Horizontal Electric Motor or Gear Drive

Materials: ..... Cast Iron and other materials available upon request

# Vertical Lineshaft Turbine Pumps



**KAG-KEL**



**NEMITSAS PUMP**  
Open Line-Shaft  
Threaded Column

Introducing a complete KAG and KEL series of engineered cast discharge head, designed to meet the needs of our customers.

- Heavy Duty - Designed for stability.
- Designed to Reduce Hydraulic Friction Losses.
- Discharge columns and shafts can be accommodated within wide limits in these designs.
- The rotation is anticlockwise and a ratchet prevents reverse rotation.

## **Specifications – For greater depths please consult the manufacturer.**

Capacities: ..... @ max flow up to 600 m<sup>3</sup>/hr

Head: ..... @ zero flow up to 460 meter

Horsepower: ..... Up to 600 hp

Temperature: ..... Up to 82 °C

Drives: .....With Vertical Electric Motor or Gear Drive

Materials: ..... Cast Iron and other materials available upon request

# Vertical Lineshaft Turbine Pumps

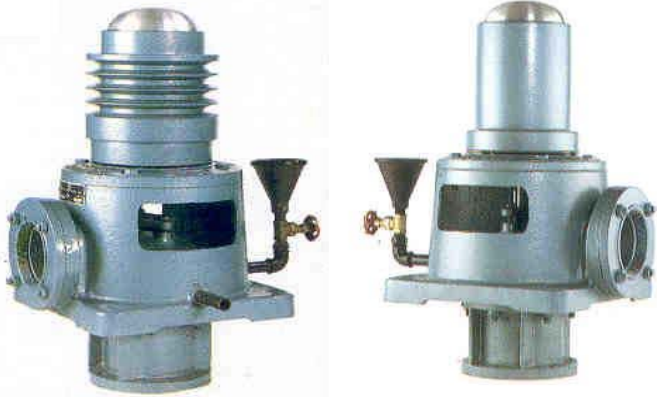

**NEMITSAS PUMP**  
Open Line-Shaft  
Flanged Column



Introducing a complete SF and SV series of engineered cast discharge heads, designed to meet the needs of our customers.

- Heavy Duty - Designed for stability.
- Designed to Reduce Hydraulic Friction Losses.
- Discharge columns and shafts can be accommodated within wide limits in these designs.
- The rotation is clockwise and a ratchet prevents reverse rotation.

## **Specifications – For greater depths please consult the manufacturer.**

Capacities: ..... @ max flow up to 120 m<sup>3</sup>/hr

Head: ..... @ zero flow up to 400 meter

Horsepower: ..... Up to 120 hp

Temperature: ..... Up to 82 °C

Drives: ..... V or F Ropes with Horizontal Electric Motor or Gear Drive

Materials: ..... Cast Iron and other materials available upon request

# ***Vertical Lineshaft Turbine Pumps***



## **Pump Bowl Assembly**

The bowl assembly is the heart of the vertical turbine pump.

The impeller and diffuser type casing are designed to deliver the head and capacity that your system requires in the most efficient way possible.

The fact that the vertical turbine pump can be multi-staged allows maximum flexibility both in the initial pump selection and in the event that future system modifications require a change in the pump rating.

Submerged impellers allow pump to be started without priming.

A variety of material options allows the selection of a pump best suited for even the most severe conditions.

The vertical turbine pump satisfies the users' needs for safe, efficient, Reliable And maintenance-free operation.



# ***Vertical Lineshaft Turbine Pumps***



## ***Standard Design Features***

- 1. SUCTION BEARING** - Provided for shaft stability.
- 2. SAND COLLAR** - Prevents solids from entering suction bearing.
- 3. Strainers** - to prevent foreign objects from entering the pump.
- 4. IMPELLER** - Semi-open or enclosed for appropriate service.
- 5. Dynamic balancing** - of impellers.
- 6. TAPER LOCK** - Alloy steel for fastening impellers on 12" and smaller sizes.
- 7. PUMP SHAFT** - Heavy duty 416SS standard, available in 316SS and other alloys for strength and corrosion resistance.
- 8. DIFFUSER BOWL** - Available in a variety of cast materials.
- 9. STAGES** - Flanged and bolted or threaded together for ease of maintenance.



# ***Vertical Lineshaft Turbine Pumps***

In addition to standard features and options shown here, other features are also available.



A. Hydraulic balancing of impellers to reduce axial downthrust and achieve longer thrust bearing life.

B. Independent flushing of bowl bearings and wear rings for abrasive services.

C. Hard facing of shaft journals and bearings to protect against abrasion and increase interval between maintenance periods.

D. Interior coating on bowls for improved efficiency.

E. **SUCTION BELL** - Allows smooth entry of liquid into impeller eye, minimizes vortex formation.

F. **KEYED** - Impeller fastened onto the shaft by keyed split ring.



# Vertical Lineshaft Turbine Pumps



## Adjusting Nut

Permits exact impeller adjustment for maximum performance.

## Discharge Head

Heavy-duty head provides maximum accessibility to service packing box assembly.

## Prelude Connection

## Column Adapter

Accepts threaded or flanged column.

## Adjusting Nipple

Threads directly into column adapter.  
Head shaft stickup set exactly by threading head on column as required.

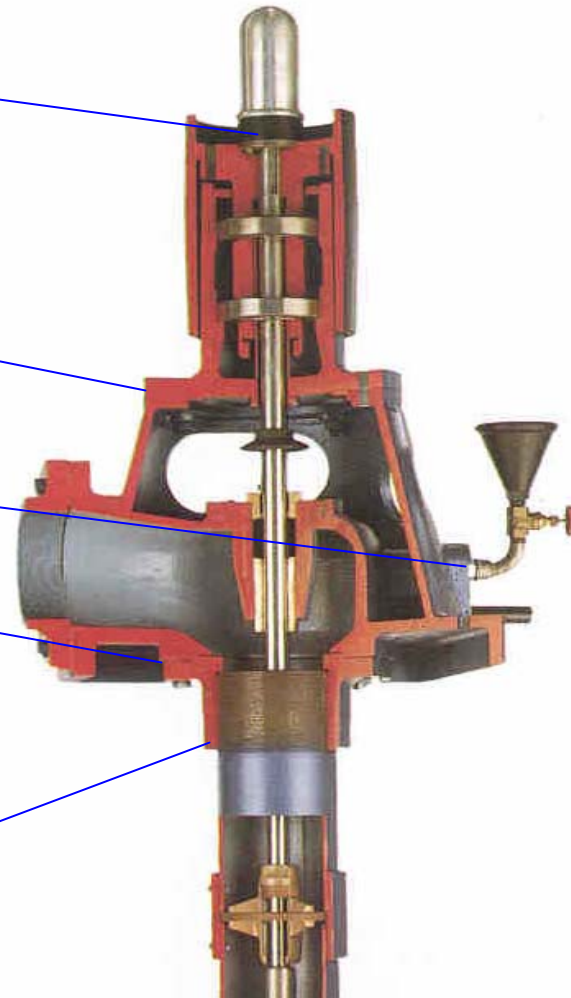

# Vertical Lineshaft Turbine Pumps



**Headshaft**  
Stainless Steel.

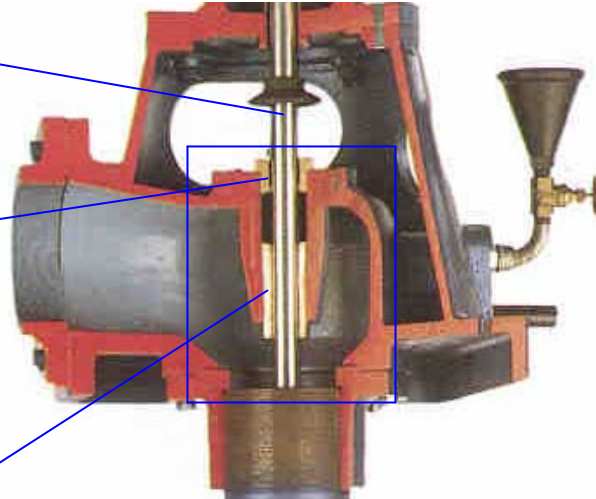

**Bronze Packing Gland**  
**Cast Iron Box**

**Throttle Bushing**  
Extra length bronze for better shaft support, longer packing life.

**Column Assembly**  
**Lineshaft**  
Available in stainless steel or carbon steel.

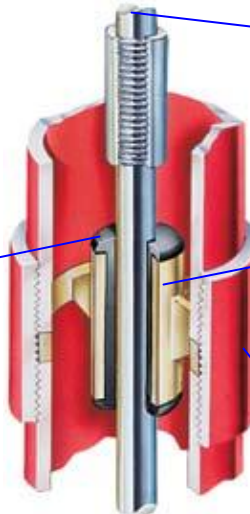

**Lineshaft Bearings**  
Fluted rubber, designed to flush sand and grit rapidly.

**Bearing Retainer**  
Bronze.

**Column Pipe and Couplings**  
Parallel thread, accurately machined for easy installation, accurate alignment.

# Vertical Lineshaft Turbine Pumps



## Pumpshaft

Nemitsas shafts are fully machined and sized for application thrust and torque. The shaft is optionally provided with a turndown, or a straight one-piece, extending through the stuffing box to eliminate the cost of an intermediate shaft coupling and guide bearing.

## Discharge Case

Connects the column pipe to the bowls keeping column and head friction losses to a minimum. Besides its hydraulic function, the case is utilized as an adaptor to suit various column and shaft sizes.

## Impellers

Impellers, closed or semi-open, are precisely trimmed and balanced to reduce vibration and wear. Impellers are located with either collet or keyed construction. Closed impellers are furnished with shrink-fitted wear rings

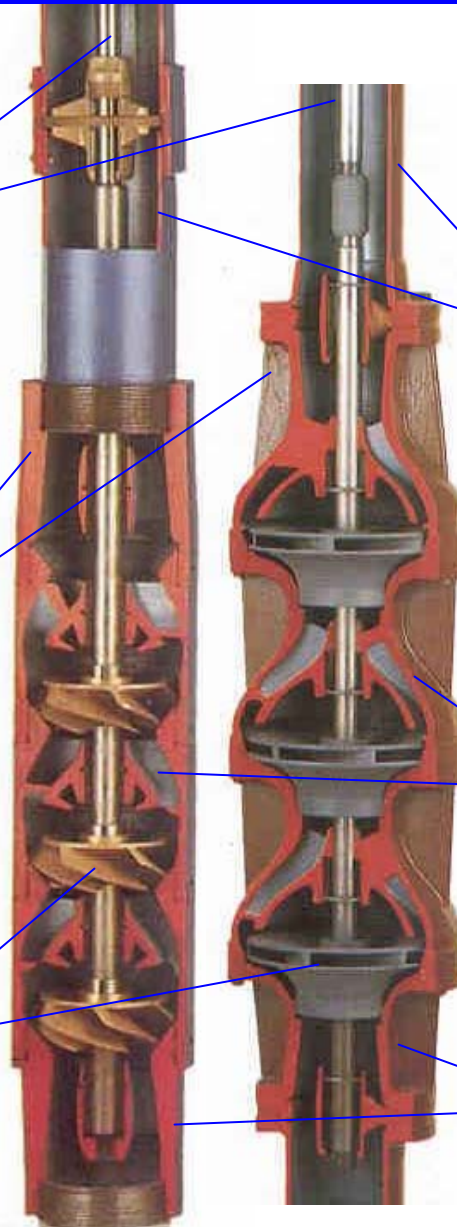

## Column Assembly

Consists of flanged or threaded connections. Product lubricated columns have a “unique” reversible bearing retainer doubling shaft life by changing wear surfaces.

## Bowls

Bowls are cast and vitriform enamelled or plastic coated as standard to achieve peak efficiency and reduce friction. Dual bronze and rubber bearings provide alignment and dampen vibration. Bowls are available in a wide range of materials.

## Suction

Available configurations including bell or suction case (for deepwell requirements), cone or basket strainers restrict large solids from entering the pump. Integral cast tail bearing.

# Vertical Lineshaft Turbine Pumps

## Pump Bowl Assembly Options



### **Enclosed Type Impeller with Tapered Collet Shaft Mounting**

Standard construction features tapered friction drive collet furnished on pump bowls through size 12".

#### **Features**

Easy installation adjustment and low hydraulic thrust.

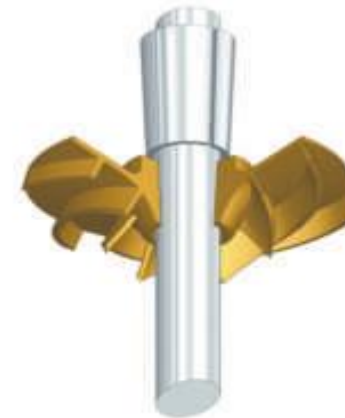

### **Semi-Open Type Impeller with Tapered Collet Shaft Mounting**

Standard construction features tapered friction drive collet. Semi-open impeller construction is available on pump bowls through size 12" and on larger sizes when required. The optional keyed type collet is available on special customer request and on applications with high starting inertia.

#### **Features**

Lateral adjustment for increasing or reducing flow rates. Reduced chances of plugging impellers when handling solids.

# Vertical Lineshaft Turbine Pumps

## Column Assemblies



SF  
TYPE



F  
TYPE



GALVANISED



RED OXIDE



### Flanged Column Assemblies

Standard construction up to 6" diameter. Flanged column pipe can be furnished in either water or product lubricated construction.

### Product Lubricated Column and Shaft Assembly

Pump setting with water levels over 30' require driver non-reverse ratchet and lineshaft pre-lubrication. Available for 3" through 12" pipe size. Most cost effective. Threaded column generally preferred for borehole pumps where well clearance is minimal.

# Vertical Lineshaft Turbine Pumps

## PERFORMANCE DATA

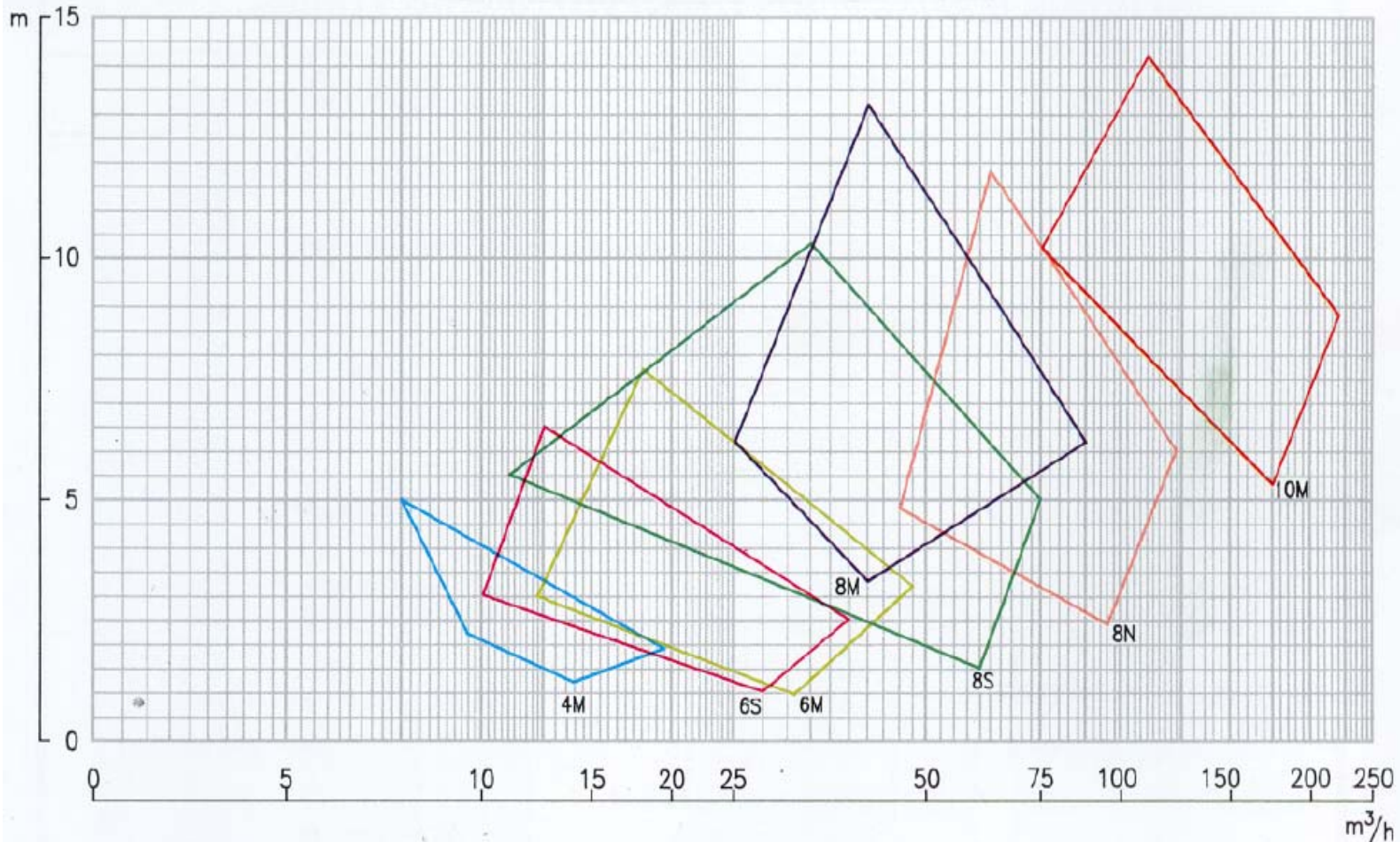

INDIVIDUAL PERFORMANCE CURVES AVAILABLE ON REQUEST

# Vertical Lineshaft Turbine Pumps

## PERFORMANCE DATA

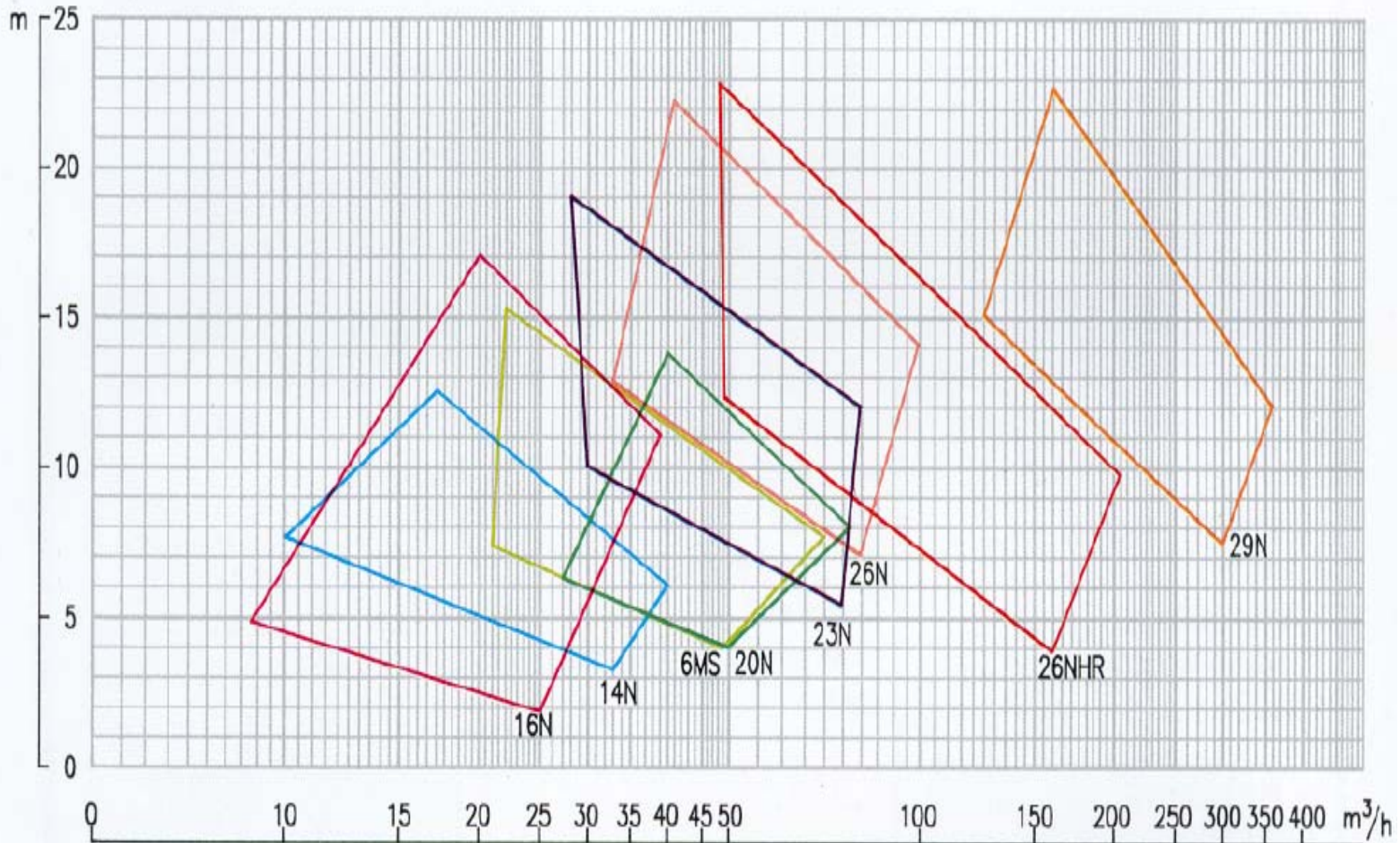

INDIVIDUAL PERFORMANCE CURVES AVAILABLE ON REQUEST

# Vertical Lineshaft Turbine Pumps

## PERFORMANCE DATA

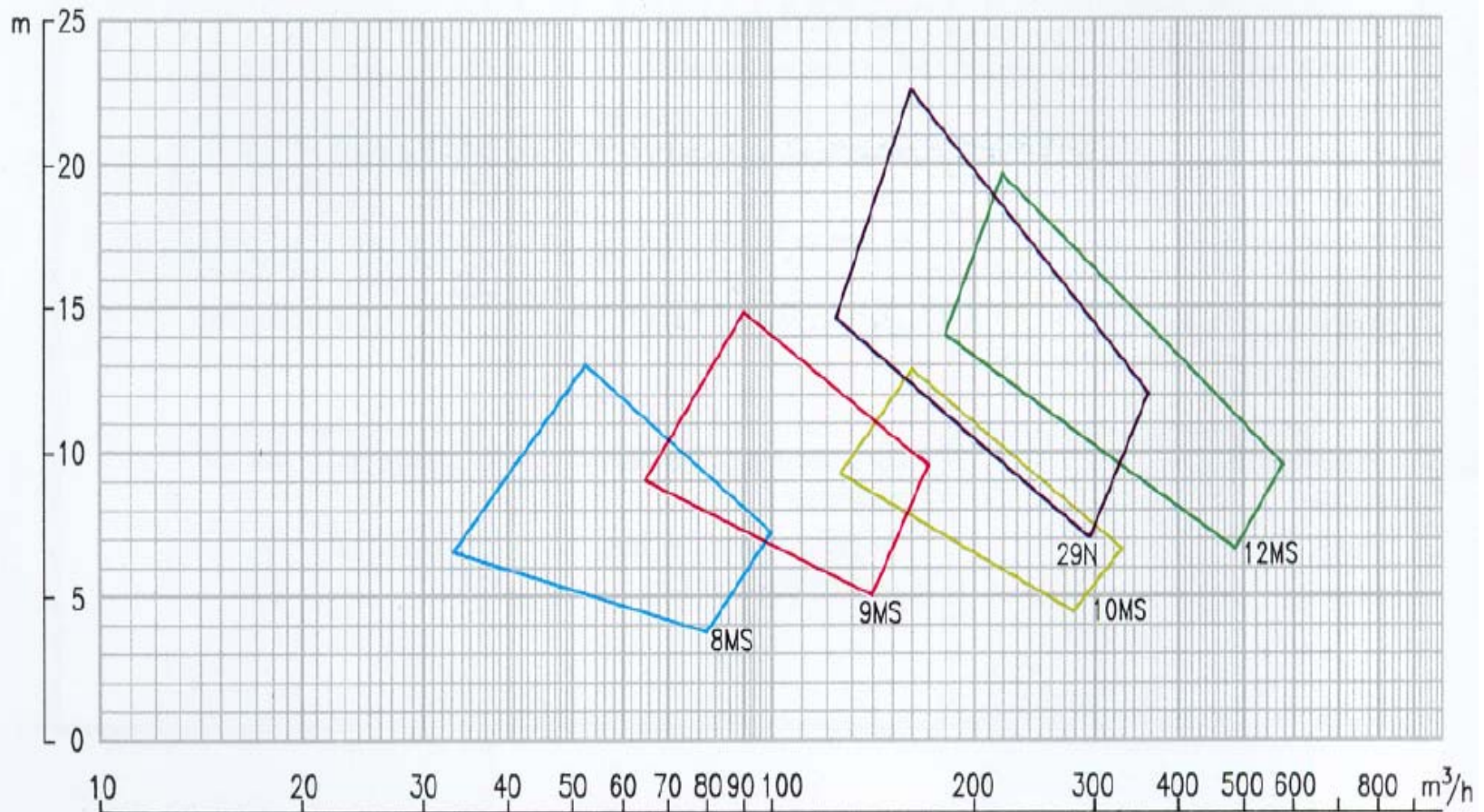

INDIVIDUAL PERFORMANCE CURVES AVAILABLE ON REQUEST